

Date: 28 September 2022

Time: 17:15 hrs

Subject: BULLETIN NO: 3

Document No: 1.3

From: The Stewards

To: All competitors / crew members

Number of pages: 2 *Attachments:* 1 (1 page)

1. Amendments to the Supplementary Regulations of the Rally

2.2 FIA Visa

FIA visa number: 11WRC/220922

Date Issued: 22.9.2022

12.3 Time Card - Control procedure and handling

FLEXI-SERVICE / SERVICE D, 30 minutes

Delete this paragraph. Saturday midday service is a normal 40-minute service for all competitors.

FLEXI-SERVICES B, 60 minutes AND ~~E~~ D, 45 minutes (correction)

12.4.5 Start intervals for Section 1 will be 3' for the first 15 cars and then 2' for all other cars.

12.7 Power Stage (add)

Notwithstanding WRC Art. 50.2, Art. 56.2.2 applies also for the regroup at TC16A/B.

12.9 Permitted early check-in at TCs

Even though early check-in at TC 1A is allowed, all priority drivers are required to fulfil their media duties first at the Media Zone.

2. Amendments to the Road Book

- Page 30 box 1 and page 33 box 6: delete Time Controls
- Pages 44 and 45, boxes 2, 6 and 10 are clarified as follows:

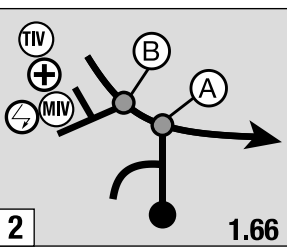
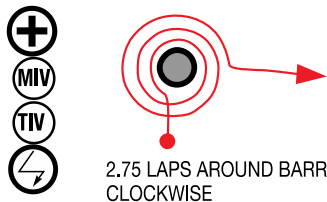
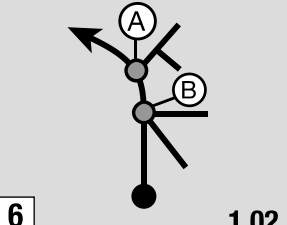
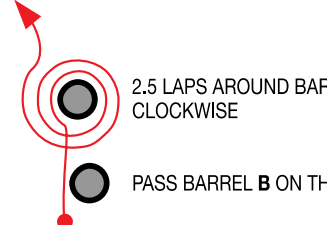
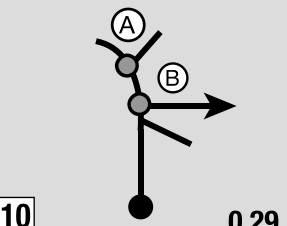
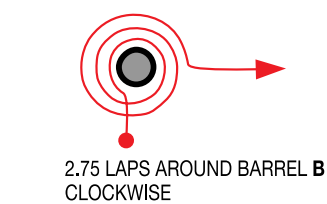





0.12	0.12			9.15
		2	1.66	2.75 LAPS AROUND BARREL A CLOCKWISE
0.76	0.11			8.51
		6	1.02	2.5 LAPS AROUND BARREL A CLOCKWISE PASS BARREL B ON THE LEFT
1.49	0.12			7.78
		10	0.29	2.75 LAPS AROUND BARREL B CLOCKWISE

- Page 108 Radio Point D is moved 100m further from box 21. New coordinates are S36°33.478 E174°31.213

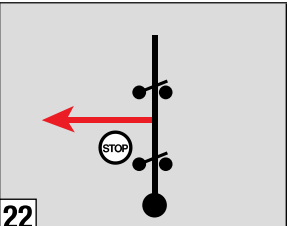
- Pages 124 - 128: the top of each page to be corrected as follows:

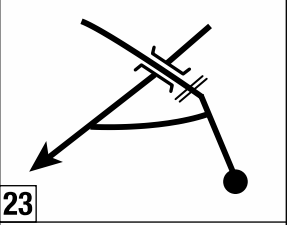
TC	TC 13E Service OUT					
13E/14	Distance	39.21 Kms	Time	1 hr 00 min	Speed	39.2 Kph

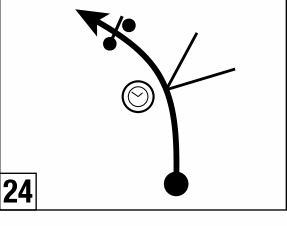
- Page 142 **for SS17 only**; all competitors are required to turn left at the Stop Control taking a short cut to the podium by following these instructions:

7.14	0.19		 SS 17	1.60
8.17	1.03		 TURN LEFT BEFORE THE BRIDGE	0.53
8.70	0.53		 TC 17A PODIUM HOLDING AREA IN EARLY CHECK-IN ALLOWED FOLLOW MARSHALS INSTRUCTIONS	0.00

Page 142

- Page 147: ignore the instruction for final scrutineering. All cars are required to first check-in at the final time control, TC 17C.
- The time controls at the Service Park are clarified in **Attachment 1**. All competitors are required to use this drawing as a reference instead of the instructions related to the location and numbering of the time controls and the media zone as described in the road book on pages 48, 49, 51, 88, 89, 93, 120, 121, 124 and 149. Circulation inside the main Service is changed to clockwise.



Mathieu Remmerie
The Stewards



Chris McMahon



Wayne Scott

